

Eyeline® Rear Projection electric screens

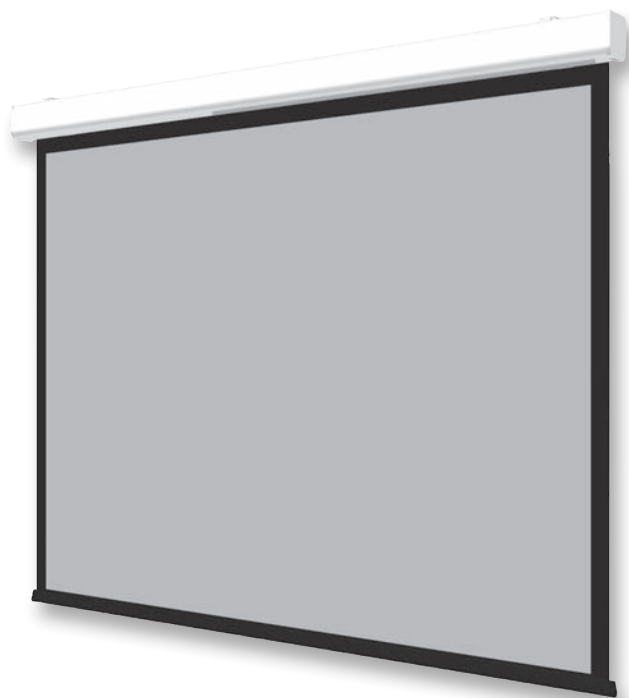

Becoming more popular each year, rear projection screens are used in environments where the projection source is sited behind the screen in order to save space or create a clear environment for the viewing audience.

2 year guarantee.

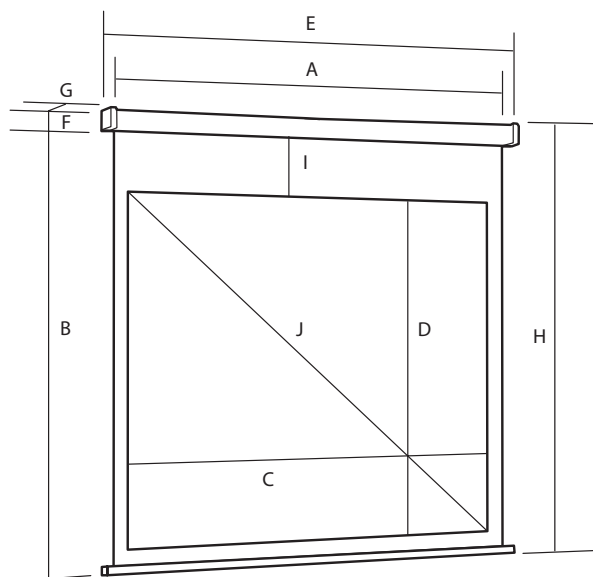

Projection format

Available in Video 4:3, Widescreen 16:9 & 16:10 Formats.

Screen material & borders

Rear projection coral screen material. 4:3 format screens are available with or without black borders. The 4:3 with black borders and 16:9 formats also have an extended black drop.

Operation

Electrically operated, supplied with a wall switch as standard. Remote operation using Radio Frequency or Infra Red signal is available as optional extras.

Installation

White powder coated aluminium case with a robust channel fix mounting system for fast, secure installations to a wall or ceiling. Motor is situated on the left hand side. Requires electrical installation.

Need a different size or material?

Different screen size, format or fabric – Please contact us for our extended range and details of our Made to Order screens.

Product Code	Dimension cm	Format	A Screen Width mm	B Screen Height mm	C View Width mm	D View Height mm	E Case Length mm	F Case Height mm	G Case Depth mm	H Overall Height mm	I Black Drop mm	J Diagonal inches	Weight kg
RPE18V	137 x 180	4:3	1800	1370	1800	1370	1880	116	112	1486	na	88	15
RPE25V	190 x 250	4:3	2500	1900	2500	1900	2580	116	112	2016	na	124	21
RPE18VB	127 x 170	4:3	1800	1570	1700	1270	1880	116	112	1686	200	84	15
RPE25VB	180 x 240	4:3	2400	2100	2400	1800	2580	116	112	2216	200	118	21
RPE18WB	95 x 170	16:9	1800	1550	1700	950	1880	116	112	1579	500	77	15
RPE25WB	135 x 240	16:9	2400	1950	2400	1350	2580	116	112	2066	500	108	21